

PAPER CRAFT

<http://www.canon.com/c-park/en/>



Subaru Telescope
SUBARU Japan National Large Telescope

View of completed model

*This model was designed for Papercraft and may differ from the original in some respects.

Assembly Instructions: Six A4 sheets (No. 1 to No. 6)

*Build the model by carefully reading the Assembly Instructions, in the parts sheet page order.

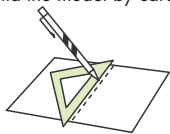

*Hint: Trace along the folds with a ruler and an exhausted pen (no ink) to get a sharper, easier fold.

Assembly Instructions



Mountain fold (dotted line)
Make a mountain fold.



Valley fold (dashed and dotted line)
Make a valley fold.



Scissors line (solid line)
Cut along the line.

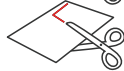

Cut in line (solid line)
Cut along the line.

Tools and materials



Scissors, set square, glue (We recommend stick glue), pencil, used ballpoint pen, toothpicks, tweezers, (useful for handling small parts)

Assembly tip



Before gluing, crease the paper along mountain fold and valley fold lines and make sure rounded sections are nice and stiff.

Caution



Glue, scissors and other tools may be dangerous to young children so be sure to keep them out of the reach of young children.

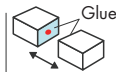

Glue
The glue spot (colored dot) shows where to apply the glue.

Red dot (Glue spot)
Glue parts with the same number together.

Green dot (Glue spot)
Glue within the same part.

Blue dot (Glue spot)
Glue to the rear of the other part.

Rules for assembling the Subaru Telescope Paper Craft

- Number each part on its backside after cutting out to avoid confusion.
- Indicates where sections should be glued together.
 Indicates where to insert sections. Do not glue the sections together.
- The grey diagonal lines indicate the portion to be cut out. Use a circle cutter to easily cut perfect circles.
- In the explanatory diagrams, indicates the backside of the paper, while indicates the margins to which glue is applied.

A

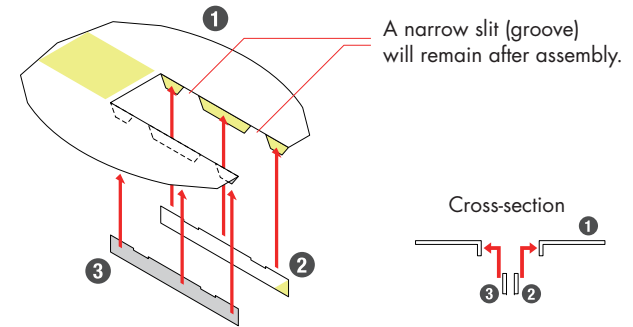

B

Glue to the backside of the paper along the periphery of the ellipse. To ensure the optimal finish, glue one flap each time, and dry in series, working from front to back.

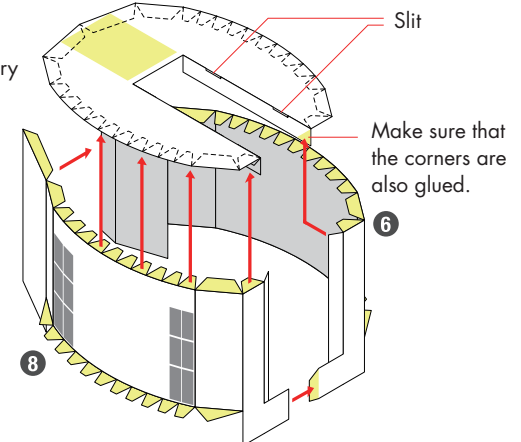

C

Glue the right and left walls from the front, moving around the body.

D

Turn over the dome and insert the bottom to the extent of the width of the area to which glue is to be applied, then glue. Take care of the front and back direction.

E

Assemble the right and left shutters. Do not glue the two upper nails of each shutter.

Do not put glue these two positions so that the two nails are left floating.

F

Insert the lower nails into the gap in the front paper, then insert the two upper nails into the slits on the ceiling. Make sure the shutter can be opened and shut freely.

G

H

Take care to ensure the top-bottom alignment of parts 11 and 12.

I

Don't forget to cut the slits.

J

After assembling 22, glue the wall. Take care to ensure the longitudinal alignment.

Glue the wall in sequence, fitting along the floor, starting from the front (carry-in entrance).

K

Glue the shutter to the inside of the dome so that the picture faces outward.

L

Mount the ceiling to the wall so that flaps to which glue is to be applied come out through the slits. Since there is no flap at the front of the dome, one slit will remain open.

Fold back the flaps inward to which glue is to be applied and apply glue.

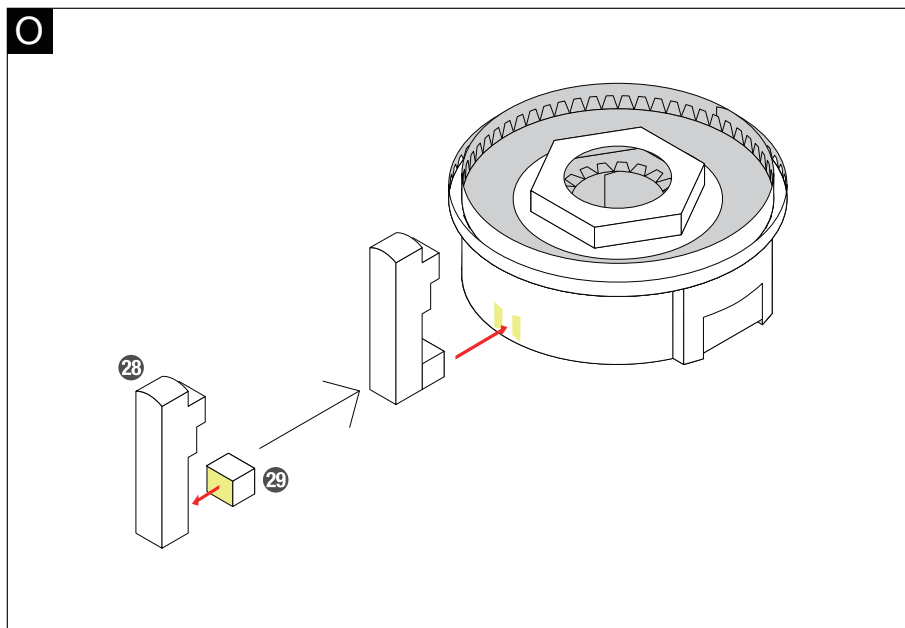
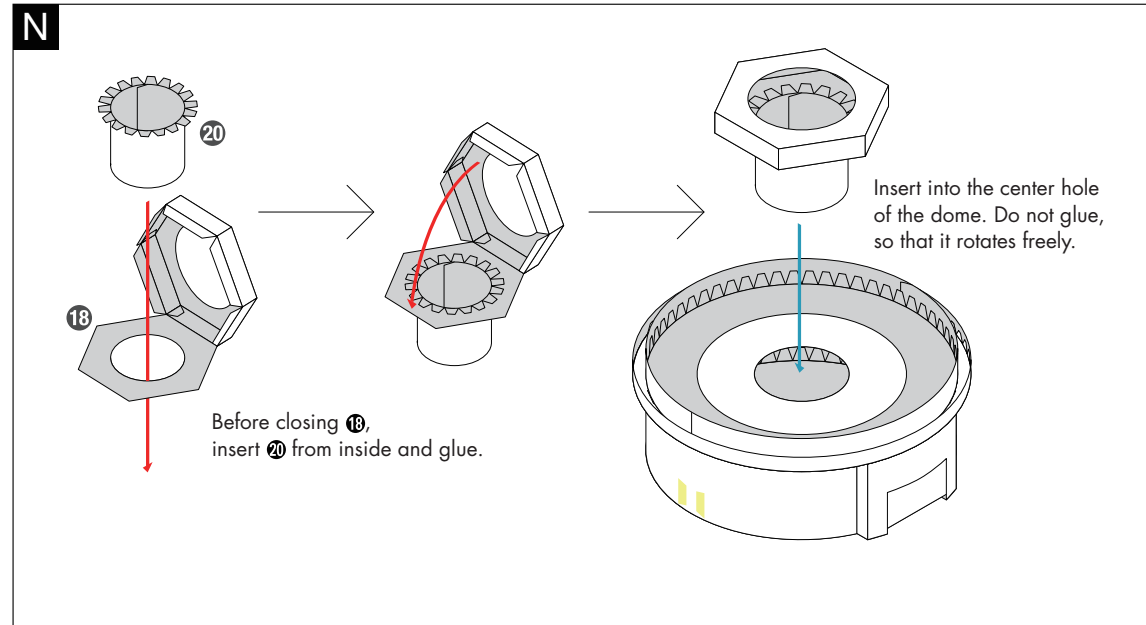
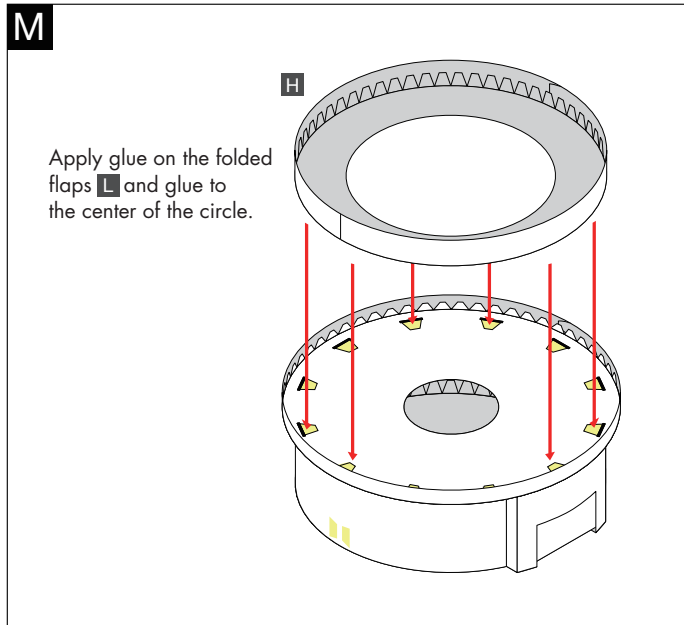

Both the upper part and lower part of the dome have been completed.
The next step is to assemble the telescope.

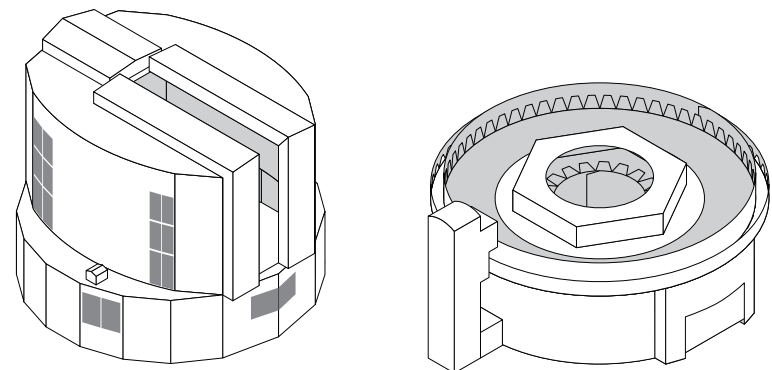

P

Fit into the ring, arranging the shape, and apply glue.

Apply a small amount of glue to the cut edge of 32 and glue so that the circle 33 is covered.

Top view

Fold arms 34 and 35 in the middle and glue together.

Q

Fit into the ring and glue.

After attaching 52, apply some glue to the cut edge of the paper and insert.

Apply glue to the cut edge of the paper and insert from the bottom, then apply pressure.

R

Apply glue to P at the areas to which glue is to be applied outside the ring and glue to 36.

S

T

Fold 55 and 56 in the middle and glue together.

Keep the surface with the hole facing in.

U

Fold up the right and left nails and insert into the holes. The nail will expand inside to fix. No gluing is required.

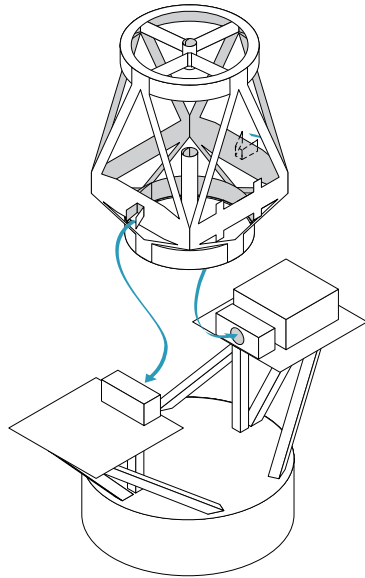

You can adjust the altitude (angle of the telescope) to any position desired.



V

Fit the telescope into the center hole of the lower part of the dome. Do not glue.

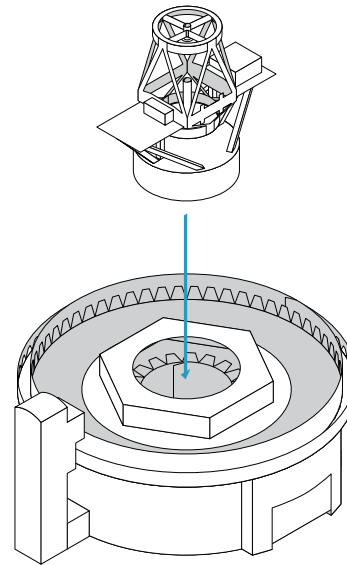

Both the telescope and the setting rack can rotate freely. For the moment, however, keep them positioned as shown below.

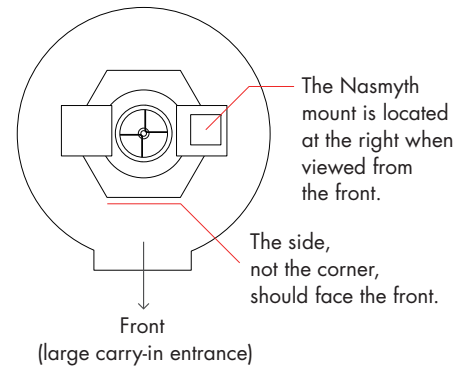

W

To complete the assembly, fit the upper dome so that the hexagons at the center engage each other, keeping the Nasmyth mount from colliding. Set up the completed model together with the plate.

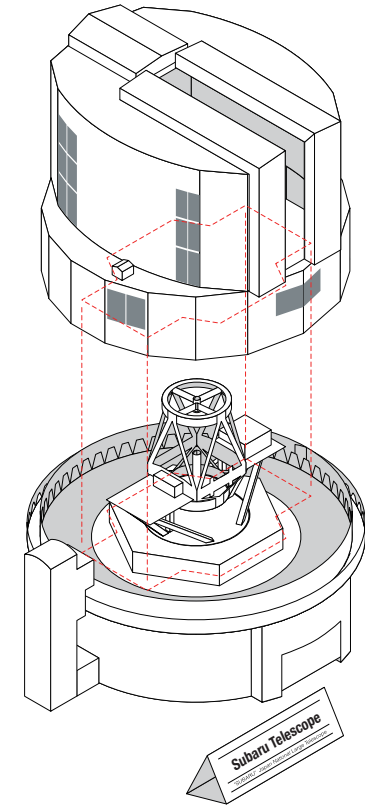

Finished!

Moving parts of the completed model.

- The shutter of the opening opens and closes.
- The upper dome revolves 360 degrees.
The telescope revolves together with the dome.
- The upper dome can be removed.
The altitude of the telescope can be adjusted.
- The telescope revolves 360 degrees.

*In the actual Subaru Telescope, the rotation of the dome and the rotation of the telescope are implemented by separate mechanisms to minimize errors in horizontal rotation.